

Short guide : TU501-x

Version 4.2, May 2019



NOTE: Former model ID was ME501-x (2G/3G). Model ID changed in 2017 to TU501-x (2G/3G)

Index

Practical Advice	3
Machine and vehicle guidelines for correct wiring	4
Installation example	5
Functionality check: LED on the unit.....	6
Installation check and update using “Verify my Trackunit”	7
Input filtering (INFILT).....	8
CAN bus termination resistor	9
Troubleshooting.....	10
Product specifications.....	11
Temperature range	12
Mechanical specifications	12
Regulatory information and precautions.....	13
Approvals and Certifications	15

Practical Advice

1. Save important numbers

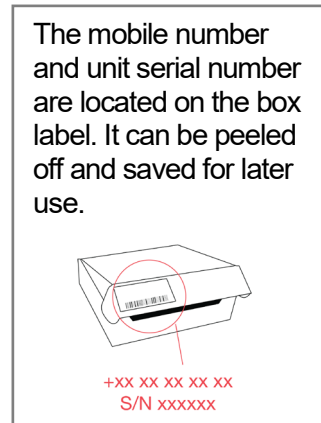
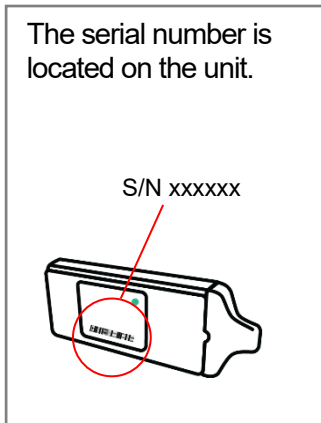

2. Installation is best done outside

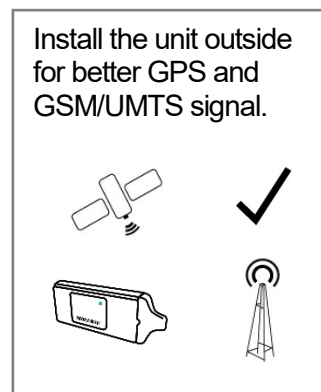
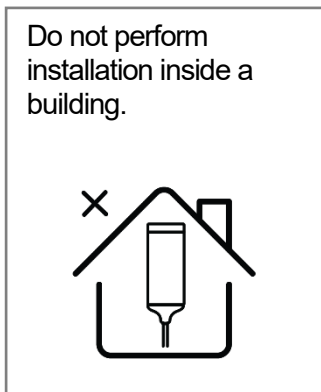

3. Correct positioning of the unit

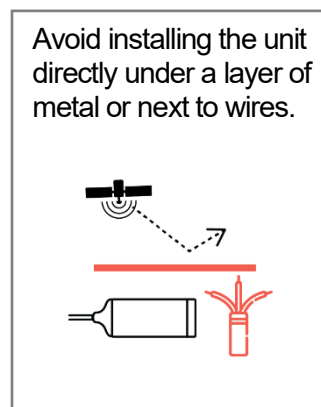
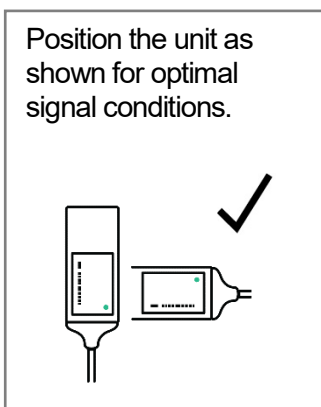

Machine and vehicle guidelines for correct wiring

Wire color	Description
Power	Connect to machine battery through a fuse (mandatory) ¹
Ground	Connect to ground (mandatory)
Digital input 1	Can be connected to hour counter. Optional input ²
Digital input 2	Connect to the ignition signal (mandatory for vehicles and machines) ¹
Digital input 3	Optional input ¹
Digital input 4	Can be used for INFILT function. Optional input ²
Digital output 1	Can be used to control a relay ^{3/4}
Additional input for TU501-2	
1 – Wire input	M8 connector for access control and temperature sensor
Additional input for TU501-4	
CAN High	Connect to CAN High
CAN Low	Connect to CAN Low
1 – Wire input	M8 connector for access control and temperature sensor

1: Supply voltage range 12–48V

2: Active/high when min. 9,5V DC at input

3: Max. load 200 mA

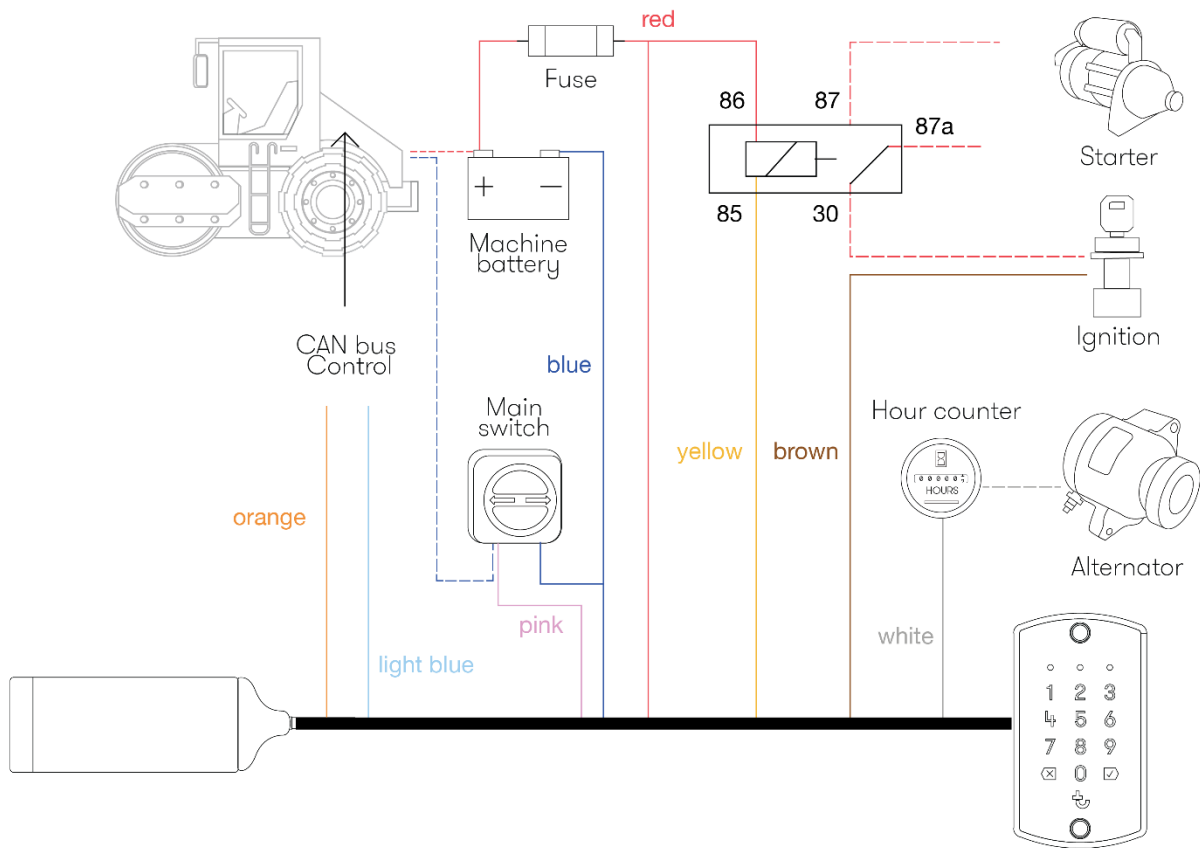

4: Do NOT use this output to switch off vehicles and machines during operation or driving

Installation example

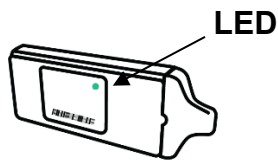

Functionality check: LED on the unit



Status	LED mode	LED color	Status indication
✓	Red flashing light and constant green light in LED		- Mobile network is OK and GPS has valid satellite position
!	No light in LED		- No power supply
!	Constant red light and no green light in LED		- Power supply is OK, but NO mobile network - GPS has NO satellite position
!	Red flashing light and no green light in LED		- Mobile network is OK - GPS has NO satellite position
!	Constant red and green light in LED		- Power supply is OK, but NO mobile network - GPS has valid satellite position

Installation check and update using “Verify my Trackunit”

Step 1: Login

- Go to <http://verify.trackunit.com>
- Enter user name and password

Step 2: Find unit

- Enter serial number and then click “Find”

Step 3: Review status

- Time of last received data
- GPS and mobile signal
- Mobile number
- Power supply voltage
- Internal battery voltage
- Status of inputs 1-4 (on/off)
- Click “Find” again to refresh status

Step 4: Basic configuration options

- Enter a device name
- Enter engine hours
- Enter start distance
- Select category
- Connect up to multiple groups
- Add a note (visible in Trackunit Manager)

Step 5: Logout

- Click “Update” to save
- Click “Logout”

Note

- Prior to verification, make sure the unit is installed and active in an area with sufficient GPS and mobile coverage.

Input filtering (INFILT)

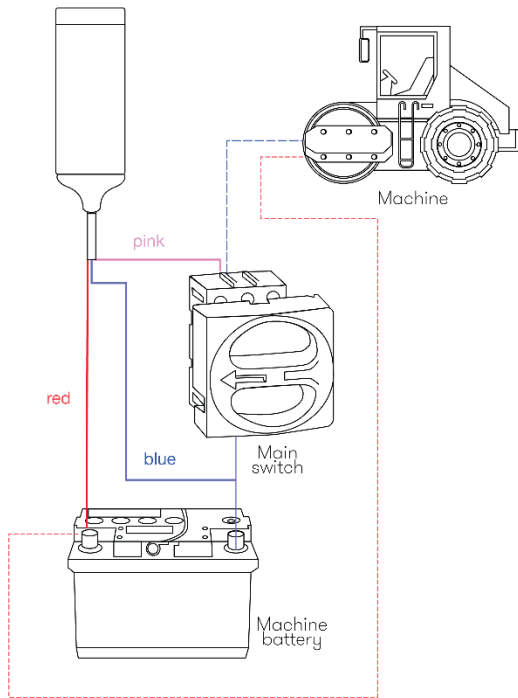

In case the main breaker is on the negative wire (ground wire from the machine battery), the inputs may register a voltage level and start counting operating hours.

To avoid this situation, the digital input 4 (pink wire) should be connected to the chassis/ground on the machine.

The infiltr function should be activated via “Verify my Trackunit”

Activation of input filtering

Go to: <http://verify.trackunit.com/>

Input Filtering: Current Status = OFF Click here to change

NB! Enabling the filtering function will disable inputs 1 to 3 when input 4 is on/active. This can prevent all digital input alarms. It will also disable the use of any alarm function on digital input 4.

CAN bus termination resistor

When installing the TU501-4 on a J1939 CAN-bus, it is very important to determine if the installation is on a “private” CAN-bus directly to the CAN controller, or if the TU501-4 is to be installed as a stub on a CAN-bus with multiple CAN devices already attached.

The 120-ohm termination resistor is a permanently installed resistor, so make sure to use and select the correct TU501-4 CAN-bus version.

With 120-ohm bus termination (directly connected)



Without bus termination (stub connected)

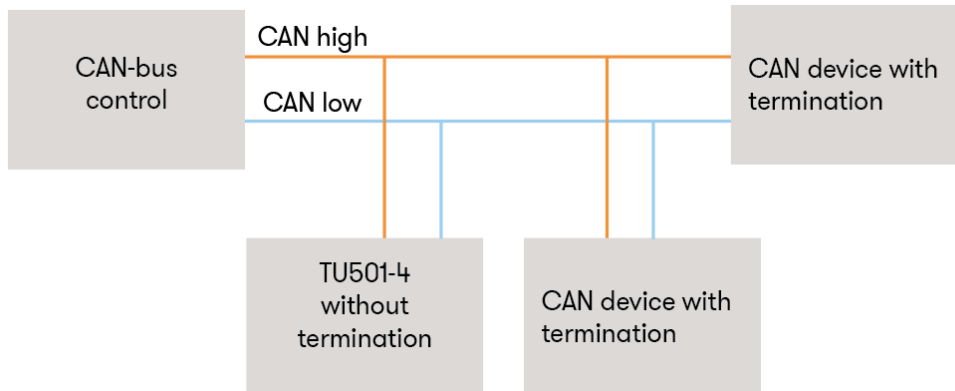

NB! When the unit is stub connected, the wire length must be minimized to avoid CAN-bus noise and error ratio.

Troubleshooting

Error description	Possible solutions
No reply on SMS command	<ul style="list-style-type: none"> • Verify correct GSM number • Check LED status – see page 6
No light in LED	<ul style="list-style-type: none"> • Check if the red and blue wires are installed correctly or if the fuse is blown
Constant red light in LED	<ul style="list-style-type: none"> • Verify location of the unit – see page 3 • Move machine or vehicle for better GSM signal
No green light in LED	<ul style="list-style-type: none"> • Verify location of the unit – see page 3 • Move machine or vehicle for better GPS reception
Inputs counting operating hours when machine is off	<ul style="list-style-type: none"> • Possibly due to the main breaker being on the negative wire (ground wire from the machine battery). When off, the inputs may register a voltage level and start counting operating hours. • To avoid this situation, the digital input 4 (pink wire) should be connected to the chassis/ground on the machine. • See Input filtering (INFILT) section, page 8.

Technical Assistance

If you experience an issue and cannot find the information you need in the product documentation, please contact Trackunit.

Trackunit support: +45 96 73 74 00

Email: support@trackunit.com

The guides can also be downloaded online: www.trackunit.com/downloads

NB! When contacting technical support, please have the unit serial number ready.

Product specifications

	TU501-9 Standard	TU501-2 Access	TU501-4 Access/CAN
2G GSM	Yes		
3G UMTS	Yes		
Operational voltage (supply voltage)	12-48 V DC		
Absolute maximum voltage range	8-58 V DC continuous		
Standby consumption (GSM-receiver active)	10 mA / 7 mA (avg. at 12V/24V)		
Consumption during charging an empty battery	225 mA / 115 mA (max at 12V/24V)		
Charging time for an empty backup-battery	4 hours at 25°C / 77°F)		
Digital inputs	4		
Digital outputs	1		
CAN inputs (High / Low)	0	0	2
Access control input M8 connector	0	1	1

Temperature range

In active running mode*	<p>-20°C to +55°C/60°C</p> <p>Limited by the Li-Ion backup battery when the unit is either machinery or battery powered.</p>
Storage**	<p>-40°C to +70°C</p> <p>Shorter battery lifetime must be expected when storage and operation occur at extreme temperatures.</p>

Mechanical specifications

Length	106 mm (4.17 in.)
Width	45 mm (49 mm incl. cradle) (1.9 in.)
Height	18 mm (23 mm incl. cradle) (0.9 in.)
Cable length	170 cm (5.6 ft.)
Environmental class	IP67
Weight	65 g (excluding cable) (2.3 oz.)

Regulatory information and precautions

Use location	This equipment design applies to commercial or industrial equipment expected to be installed in locations where only adults are normally present
Terms of use	Use only Trackunit approved accessories and/or batteries. Do not connect incompatible products
New battery	In case of battery malfunction, expiration or any other situation where a new battery might be needed, replacement batteries can be ordered through support@trackunit.com
CE mark	The TU501 products comply with the essential requirements of the RED 2014/53/EU directive with respect to the EMC requirements, safety and radio spectrum matters.
FCC mark	The TU501 products contain radio transmitters and comply with the essential requirements of Part 15, 22 and 24 of the FCC rules, and with RSS-GEN, RSS-132, RSS-133, RSS-210 and ICES-003 of the Industry Canada requirements.
Environmental	The TU501 products comply with the environmental conditions for rolling stock and transportation according to DIN EN 50125-1 and IEC 61373 / DIN EN 61373 with the IP67 classification including vibrations/drop according to SAE J1455 (heavy trucks).
Charging	The battery will recharge as long as its temperature range is within 0°C to +45°C and the vehicle to which the unit is mounted is running. In case of temperatures outside this range the internal battery will not recharge.
Operating conditions	The internal battery will operate in temperature ranges from -20°C to +60°C. In case of temperatures outside of this range the internal battery will be disabled by the device. Battery lifetime is expected to be 3 years under normal operating conditions.
Long term storage /operating conditions	It is recommended to remove the battery during long term storage/continuous operation outside the temperatures specified in the operating conditions.

<p>Fuse</p>	<p>Recommended fuse holders and fuses for installation up to 48V supply voltages (can be ordered at Trackunit A/S):</p> <ul style="list-style-type: none"> a. Supply voltage 12V/24V (Max 30A) <ul style="list-style-type: none"> i. ATO blade fuses (Max 32V/1A) used with Littelfuse FHAC0002SXJ fuse holder (standard). ii. ATP blade fuse (Max 32V/1A - ATO style) used with TaiTek FH-006WR-12R-12-U fuse holder (standard). b. Supply voltage 12V - 48V (Max 30A) <ul style="list-style-type: none"> i. FKS blade fuse (Max 80V/3A - ATO style) used with Littelfuse FH2 fuse holder (recommended).
<p>Machinery</p>	<p>The TU501 products comply with the essential requirements of the Directive 2006/42/EC and EU regulation 167/2013 when integrated as intended:</p> <ul style="list-style-type: none"> I. EN 13309 Construction machinery II. ISO 13766 Earth-moving machinery III. EN/ISO 14982 Agricultural and forestry machines. IV. UN regulative ECE R10 EMC rev. 4 in accordance with EU regulation 661/2009 for Electronic Sub-Assembly (ESA). <p>NOTE: Harmonized standards under the directive 2014/30/EU have been applied.</p>

Approvals and Certifications

<p>FCC/IC part 15.19 Notice</p>	<p>This device complies with Part 15 of the FCC Rules and with Industry Canada license-exempt RSS standard(s). Operation is subject to the following two conditions: (1) this device may not cause harmful interference, and (2) this device must accept any interference received, including interference that may cause undesired operation.</p>
<p>IC RSS-GEN Notice</p>	<p>Le présent appareil est conforme aux CNR d'Industrie Canada applicables aux appareils radio exempts de licence. L'exploitation est autorisée aux deux conditions suivantes: (1) l'appareil ne doit pas produire de brouillage, et (2) l'utilisateur de l'appareil doit accepter tout brouillage radioélectrique subi, même si le brouillage est susceptible d'en compromettre le fonctionnement.</p>
<p>FCC part 15.21 Notice</p>	<p>Changes or modifications made to this equipment not expressly approved by Trackunit may void the FCC authorization to operate this equipment.</p>
<p>FCC/IC Radiofrequency radiation exposure Information</p>	<p>This equipment complies with FCC/IC radiation exposure limits set forth for an uncontrolled environment. This equipment may be installed and operated with minimum distance of 5 cm between the radiator and your body. This transmitter must not be co-located or operating in conjunction with any other antenna or transmitter.</p>
<p>Environmental compliance</p>	<p>IEC 61373 - EN/IEC 60068-2-1:2007 - Cold IEC 61373 - EN/IEC 60068-2-2:2006 - Dry Heat EN 50125-1 - EN/IEC 60068-2-27:2010 - Shock SAE J1455 - EN/IEC 60068-2-31:2008 - Drop EN 50125-1, SAE J1455 - EN/IEC 60068-2-64:2008 - Random vibration IEC 61373 - EN/IEC 60068-2-78:2001 - Damp heat steady state IEC 61373 - (IEC 60529+A1+A2) CSV:2013 - Degrees of protection (IP code): IP67</p> <p>NOTE A: The TU501 is not to be mounted in areas with presence of motor oil, gasoline, diesel fuel, hydraulic fluid, brake fluid, transmission fluid, glycol and water mixture, etc.</p> <p>NOTE B: The housing is not designed to withstand high pressure cleaning. Only use the TU501 when mounted inside the designated Trackunit protection cap (7402.9551 Trackunit Raw hardware shield can be ordered at Trackunit) in mounting areas where high pressure cleaning is common procedure.</p>

<p>Regulatory labeling</p>	
<p>PTCRB certification for interoperability with mobile networks</p>	<p>Selected variants of the TU501 products series under FCC ID: ZMF-ME501 and IC: 9746A-ME501 are certified for PTCRB interoperability with mobile networks:</p> <p>#47125: Trackunit ME501-5 (New model ID: TU501-5) #54393: Trackunit ME501-4 (New model ID: TU501-4) #54394: Trackunit ME501-9 (New model ID: TU501-9)</p>
<p>Japan</p>	<p>ID n°: [R] 003-150064, [T] D150059003</p> <p>This device is granted pursuant to the Japanese Radio Law (電波法) =当該機器には電波法に基づく、技術基準適合証明等を受けた特定無線設備を装着している</p> <p>This device should not be modified (otherwise the granted designation number will become invalid) 本製品の改造は禁止されています。(適合証明番号などが無効となります。)</p>
<p>Chile</p>	<p>Este equipo cumple con la Resolución No 403 de 2008, de la Subsecretaria de telecomunicaciones, relativa a radiaciones electromagnéticas.</p>
<p>Regulatory accessed countries</p>	<p>The regulatory accessed countries are countries without local registrations or approvals. The following countries are accessed: Americas: Chile Middle East: Israel Asia: Myanmar, India</p>